



PRODUCT CATALOG



OUR STORY

Miopaper is one of the largest private enterprises in the Turkish paper and cardboard industry.

Miopaper was founded in 2009. Today, Miopaper is an exemplary company certified by the Ministry of Environment for fully environmentally-friendly operations in constant communication with relevant stakeholders. Miopaper always puts their customers first and presents qualified products.



Our products are produced in accordance with quality standards by recycling waste paper. It has capacity of high-standard production, Miopaper supply with all your needs for paperboard, a light, economic and recycled packaging material.

Top quality products are used. Quality certificates of all products used in production are delivered to customers. We make this belief a reality by putting clients first, leading with exceptional ideas, doing the right thing, and giving back.



OUR MISSION

To make your business more valuable with a variety of functional products which have specifications such as budget friendly, 100% Recyclable, ease of use for different settings in the stationery, food, furniture, logistics, pastry, printing and packaging sectors.



COREBOARD

- Thickness: 2.0-10 mm
- Length: 50-7000 mm



Jumbo Bobin Coreboard Production

Using quality raw materials, we are precisely transforming the dough into jumbo cardboard bobbins with new technologies. NOW with our new facility we produce from 260 gsm to 480 gsm and 120cm diameter.

PRODUCT SPECIFICATION

Basis Weight	Thickness	Diameter	Moisture $\pm 1\%$	Tube Diameter
280 $\pm 4\%$	440 $\pm 5\%$	120 ± 1	6,50	76 mm
300 $\pm 4\%$	500 $\pm 5\%$	120 ± 1	6,50	76 mm
320 $\pm 4\%$	550 $\pm 5\%$	120 ± 1	6,50	76 mm
380 $\pm 4\%$	600 $\pm 5\%$	120 ± 1	6,50	76 mm
400 $\pm 4\%$	620 $\pm 5\%$	120 ± 1	6,50	76 mm
420 $\pm 4\%$	650 $\pm 5\%$	120 ± 1	6,50	76 mm



Type	Unit	Coreboard
Width (w)	mm	500 - 1460
Weight	gr/m ²	280 - 420
Thickness (t)	μm	440 - 650

PACKAGING STANDARD

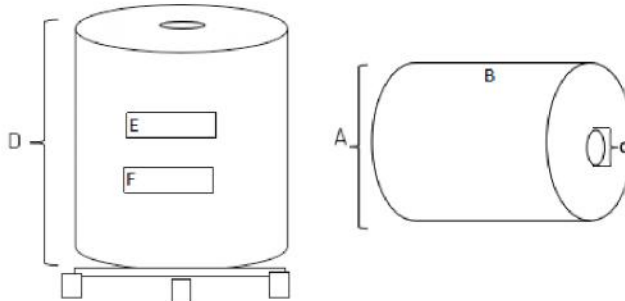

- A- OUTER DIAMETER
- B- WIDTH
- C- TUBE DIAMETER
- D- PALLET HEIGHT
- E- PRODUCT LABEL
- F- DELIVERY PRODUCT



Slitted Coreboard

It is designed in accordance with the demands of our customers with its different dimensions and gsm features.

CARDBOARD

- **Width: 350-1400 mm**
- **Length: 500-2500 mm**



GRAY CARDBOARD



WHITE CARDBOARD

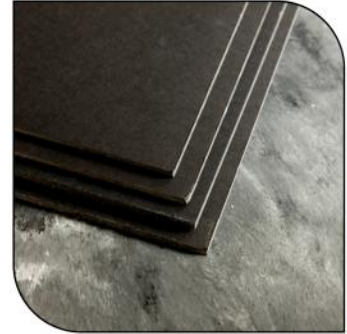

BLACK CARDBOARD



GRAY DIMENSION
CARDBOARD
(SINGLE LAYER)



CARDBOARD COVERS
(SPECIAL CUT)



PASTRY COASTER

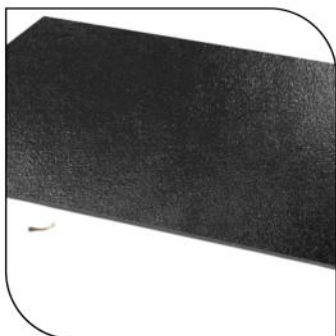

BLACK METALLIZED
CARDBOARD



SILVER METALLIZED
CARDBOARD



GOLD METALLIZED
CARDBOARD

KRAFTLINER & TESTLINER



Kraftliner & Testliner Production

It's capacity of high-standard production, Miopaper addresses all your needs for paperboard, a light, economic and recycled packaging material..

- WHITE PELLUR:** Produced in 33 gsm/m² weight with white color waste paper and optical bleach.
- WHITE SULPHITE:** Produced between 45 and 150 gsm/m² weight range. Cobb60: 20-40 g/m²
- SECOND QUALITY SULPHITE:** Produced between 50 and 150 gsm/m² weight range with optical bleach and has high strength.
- BROWN SULPHITE:** Produced between 50 and 150 gsm/m² weight range by mixed waste paper.
- IMITATION MG KRAFT: (WITHOUT COBB)** Produced between 80 and 150 gsm/m² weight range.
- IMITATION MG KRAFT: (WITH COBB)** Produced between 80 and 150 gsm/m² weight range. Cobb60: 20-40 g/m²
- FIRST QUALITY KRAFT :** Produced between 43 and 150 gsm/m² weight range .
- SECOND QUALITY KRAFT:** Produced between 50 and 150 gsm/m² weight range with brown paint.Cobb60: 20-40 g/m²
- YELLOW SHAMUA :** Produced in 50 gsm/m² weight range with yellow paint. Cobb60: 20-40 g/m²
- BLUE PELLUR:** Produced in 45 gsm/m² weight range with blue paint.
- PINK PELLUR:** Produced in 45 gsm/m² weight range with pink paint.
- PINK COVERING:** Produced in 150 gsm/m² weight range with pink paint.

- FLUTING:** Produced between 110 and 200 gsm/m².
- BROWN TESTLINER:** Produced between 110 and 200 gsm/m² and one side brown colored.
Cobb60: 20-40 g/m²
- NSSC:** Produced by double layers between 110 and 200 gsm/m² ,
resistant to cold weather conditions and has high strength.
Cobb60: 20-30 g/m²
- KRAFTLINER:** Produced by double layer between 125 and 200 gsm/m² with waste of kraft
paper and has high strength.
Cobb60: 20-40 g/m²
- WHITE TESTLINER:** Produced in 125 gsm/m² weight with high opacity and high strength.
Cobb60: 20-40g/m²
Roughness: 700-1000 ml/mil ,Brightness : %70-75

KRAFTLINER & TESTLINER



YELLOW SHAMUA



FIRS QUALITY
SHAMUA



FIRST QUALITY
KRAFT



SECOND QUALITY
KRAFT



IMITATION KRAFT



WHITE PELLUR



SECOND QUALITY
SULPHITE



EKSTRA WHITE
SULPHITE



IMITATION KRAFT



BROWN SULPHITE



PINK PELLUR



PINK COVERING



BLUE PELLUR



WHITE TESTLINER



FLUTING



BRUNET TESTLINER

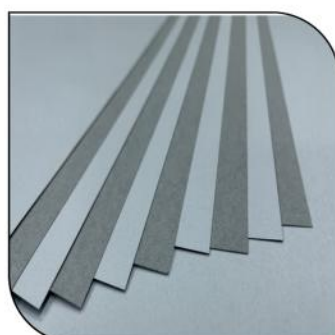

DUPLEX - GD

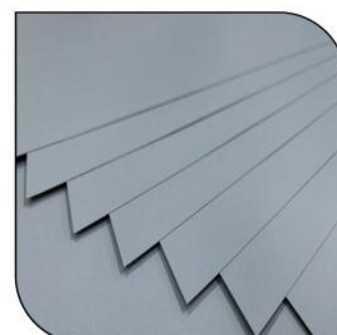

TRIPLEX - GT

EDGE PROTECTORS

- Thickness: 2.0-10 mm
- Length: 50-7000 mm



KRAFT
EDGE PROTECTOR



WHITE
EDGE PROTECTOR

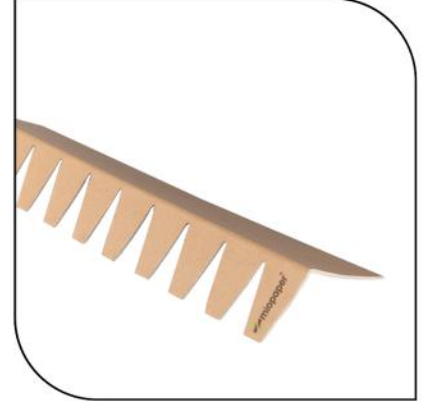

NOTCHED
EDGE PROTECTOR



LOCKED
EDGE PROTECTOR



WET-PROOF
EDGE PROTECTOR



ADHESIVE
EDGE PROTECTOR



U PROFILE
EDGE PROTECTOR

CORRUGATED & HONEYCOMB



CORRUGATED ROLL



HONEYCOMB CORRUGATED
CARDBOARD PANEL



HONEYCOMB WRAPPING PAPER
ORG. KRAFT
WIDTH: 38-50CM
LENGHT: 50-100-200-250M



HONEYCOMB WRAPPING PAPER
IMT. KRAFT
WIDTH: 38-50CM
LENGHT: 50-100-200-250M



Thank you!

We make this belief a reality by putting clients first, leading with exceptional ideas, doing the right thing, and giving back.

info@miopaper.com – sales@miopaper.com

Tel: +90 312 394 39 25 – Mob: +90 535 275 56 66

www.miopaper.com